

# DeVilbiss

By Binks



## DVI Clearcoat Spray Gun

### Experience the Next Generation of Clearcoat Application

Experience the next level of precision with the DVI Clearcoat Spray Gun, the newest member of the groundbreaking DVI lineup. Designed for excellence, this spray gun ensures unmatched consistency and enhances the application of the top clearcoats on the market. Elevate your spraying technique and achieve flawless results every time!

The DVI Clearcoat gun features the all-new DVI-C1 PLUS Clearcoat Air Cap, delivering superior high-efficiency performance for a flawless finish. This air cap distributes even, super-fine particles in a consistent, homogeneous pattern to lay the clear flat, allowing painters to easily wet up a surface while minimizing runs and sags on vertical panels. The all-new fluid tip design increases fluid flow while stabilizing air flow, minimizing material usage and providing significant paint savings.

With a new black matte finish, the DVI Clearcoat boasts a better grip for easy handling, ensuring maximum comfort on the job, while providing more power for higher productivity.

Through faster performance, proven paint savings and superior atomization, the DVI Clearcoat Spray Gun gives painters the confidence to know that they can achieve a high-quality, glass-like finish every time.

#### FEATURES

- Delivers ultimate clearcoat application performance
- Sprays a uniform pattern that lays the clear flat and easily wets up a surface
- Atomizes effortlessly, producing an even distribution of super-fine particles
- Provides maximum comfort and easy use from set-up through the entire spraying process
- Provides improved transfer efficiency and saves time completing each job

# DVI Clearcoat Spray Gun

## DVI CLEARCOAT SPRAY GUN SYSTEM COMPONENTS & ORDER NUMBERS

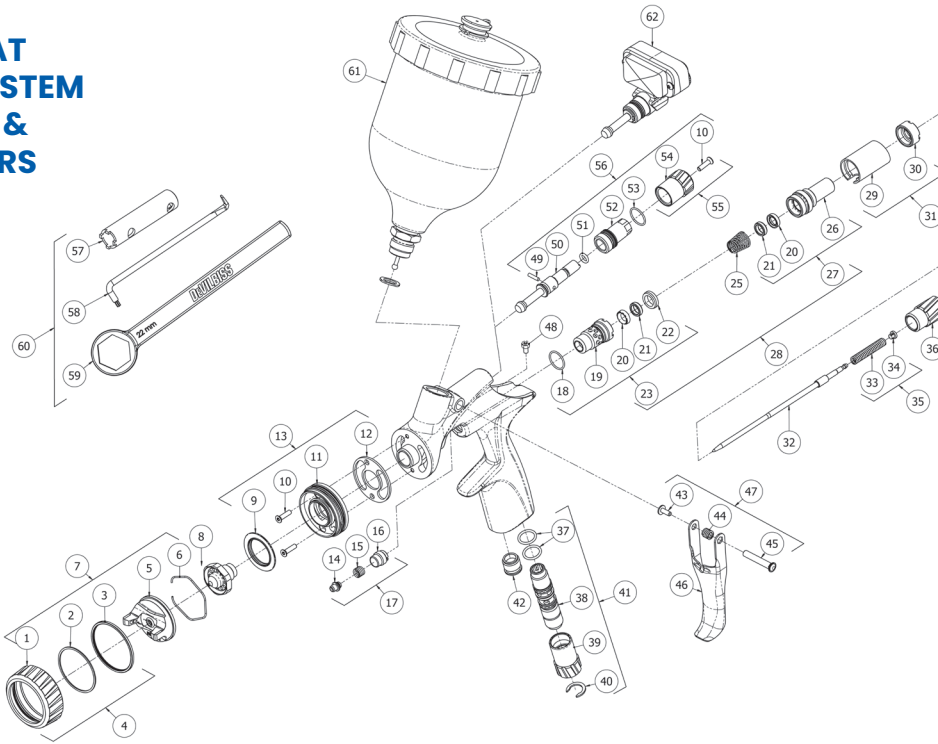

PARTS LISTING			
IMAGE REFERENCE	PART NUMBER	DESCRIPTION	QTY
1	-	Retaining Ring	1
2	-	Slip Ring	1
3	-	Retaining Ring Seal	1
4	704425	Retaining Ring Sub Assembly	1
5	-	Air Cap	1
6	191972	Spring Clip (Kit of 10)	1
7	See Table 1	Air Cap & Retaining Ring	1
8	See Table 2	Fluid Tip	1
9	704402	Deflector Plate	1
10+	704403	Screw (Kit of 3)	3
11	-	Sprayhead	1
12+	704401	Gasket (Kit of 2)	1
13	704436	Spray Head Kit	1
14	-	Needle Packing	1
15	-	Packing Spring	1
16	-	Packing Nut	1
17+	702731	Packing, Spring & Packing Nut Kit	1
18	-	O Ring	1
19	-	Air Valve Cage	1
20	-	Seal	2
21	-	Seal Guide	2
22	-	Valve Seat	1
23#	704422	Front Cage Assembly	1
24	-	Air Valve Stem	1
25#	-	Air Valve Spring	1
26	-	Rear Seal Housing	1
27	704423	Rear Seal Assembly	1
28+	704424	Air Valve Assembly	1
29	-	Identification Sleeve	1
30	-	Sleeve Nut	1
31	704437	Sleeve Kit	1
32	See Table 2	Fluid Needle	1
33	-	Needle Spring	1

PARTS LISTING			
IMAGE REFERENCE	PART NUMBER	DESCRIPTION	QTY
34	-	Spring Pad	1
35#+	704405	Needle Spring Kit	1
36	704404	Fluid Adjusting Knob	1
37	-	O Ring	2
38	-	Flow Valve Body	1
39	-	Flow Valve Knob	1
40	-	Circlip	1
41	704417	Inline Flow Valve	1
42	-	Plug	1
43	-	Trigger Screw	1
44	-	Spring	1
45	-	Trigger Stud	1
46	-	Trigger	1
47	704406	Trigger, Stud, Spring & Screw Kit	1
48	-	Screw	1
49	-	Spreader Valve Pin	1
50	-	Spreader Valve Stem	1
51#+	-	O Ring	1
52	-	Valve Body	1
53#+	-	O Ring	1
54	-	Spreader Valve Adjusting Knob	1
55	704419	Spreader Knob Kit (Not for use with digital gauge)	1
56	704418	Spreader Valve Assembly	1
57	-	Valve Tool	1
58	-	Torx Driver	1
59	-	Tip Wrench	1
60	704429	Tool Kit	1
61	GFC-501	Gravity Cup Plastic (Shown)	1
62	704426	ATEX Approved Digital Pressure Gauge	1
	704430	Minor Service Kit Includes Items Marked #	
	704431	Major Service Kit Includes Items Marked +	

TABLE 1: PERFORMANCE GUIDE	
Air Cap Part Number	704434
Air Cap & Type	DVI-CI Plus (HVL P)
Recommended Air Pressure at Digital Gauge	1.5 bar (22 psi)
Air Consumption	285 L/min (10.0 scfm)
Fluid Flow	140 - 190 g/min
Pattern Height	325 mm (12.8 in)

TABLE 2: TIPS & NEEDLES					
PART NUMBER	FLUID TIP			NEEDLE	
	SIZE	MARKING	PART NUMBER	MARKING	
704440	1.0	DVI-1.0 C			
704441	1.1	DVI-1.1 C			
704442	1.2	DVI-1.2 C	704416	DVI-300	
704443	1.3	DVI-1.3 C			
704444	1.4	DVI-1.4 C			

SPRAY GUN WITH DVI-CI PLUS AIR CAP		
ORDER NUMBER	GAUGED	CUP TYPE
DVI-C-BAR-XX-C1 +	X	GFC-501
DVI-U-BAR-XX-C1 +	X	Un-cupped
DVI-C-000-XX-C1 +	-	GFC-501
DVI-U-000-XX-C1 +	-	Un-cupped

Tip/needles available: 1.0, 1.1, 1.2, 1.3, and 1.4 mm



**A powerful solution  
can start with a  
simple conversation**

For more information, visit [binks.com](https://www.binks.com).



Learn more about what we can offer by reaching out to your local representative.

**Americas** 1.800.992.4657 | [marketing@binks.com](mailto:marketing@binks.com)  
**EMEA** 44.0.120 257.1111 | [marketing-eu@binks.com](mailto:marketing-eu@binks.com)  
**China** 86.21.33730108 | [mkt\\_cn@binks.com](mailto:mkt_cn@binks.com)  
**Japan Sales Office** 81.45.785.6421 | [jp-rans-tokyosales@binks.com](mailto:jp-rans-tokyosales@binks.com)  
**Japan Binks/DeV** 81.45.785.6421 | [jp-binks-devi@binks.com](mailto:jp-binks-devi@binks.com)  
**India/SE Asia** 44.0.120 257.1111 | [marketing-roa@binks.com](mailto:marketing-roa@binks.com)

©2025 Binks. Models and specifications subject to change without notice. All rights reserved. Form No. 09-476-01